

PHOTOELASTIC STUDY OF THE INFLUENCE OF OIL FILM ON CONTACT STRESSES

JACEK STUPNICKI

Technical University of Warsaw, Faculty of Mechanical and Power Engineering

(Received 31 October 1969, and in revised form 29 September 1970)

Summary—The paper describes some experiments, the object of which was to determine the stress distribution at a contact surface or below of it. Plastic and glass cylinders were rolled on the inner surface of a hardened steel ring under dry and lubricated conditions. The ring and the cylinder were driven by separate motors to enable rolling and sliding contact.

The maximum pressure at the contact point was, according to Hertz theory, $p_0 = 4300$ psi for a plastic model and $p_0 = 30,000$ psi for a glass model.

Direct comparison, for a given load, of isochromatic patterns for dry and lubricated conditions testify that the oil film exerts an influence on the stress distribution in the contact zone, the discrepancy with the Hertzian distribution being considerable.

NOTATION

- E Young's modulus
 E' reduced Young's modulus defined as $1/E' = \frac{1}{2}[(1-\nu_p^2)/E_p + (1-\nu_w^2)/E_w]$
 F fringe value of the model
 n fringe order
 p_0 maximum pressure according to Hertz' theory
 R_p radius of the track of the ring
 R_w radius of the cylinder
 R radius of the equivalent cylinder near the plane defined as $1/R = 1/R_w + 1/R_p$
 τ shear stress
 $\mathcal{K} = (\tau_{\max} \text{ with oil} / \tau_{\max} \text{ dry})$, shear stress coefficient
 V_p surface velocity of the track of the ring
 V_w surface velocity of the cylinder
 μ_0 viscosity of fluid at atmospheric pressure and test temperature
 α pressure, viscosity coefficient in $\mu = \mu_0 e^{\alpha p}$
 $\beta = (V_w/V_p) - 1$, slip coefficient
 ν Poisson's ratio

INTRODUCTION

It is generally known that despite the high value of the pressure at the contact point between the rolling element and the race of a lubricated ball or roller bearing or between the teeth of a toothed gear, reaching according to Hertz' theory $p_0 = 150,000$ psi, there is still a continuous oil film, a few microns thick, separating the two co-working surfaces and carrying the entire load.

The question as to whether this layer produces a stress distribution different from that for dry contact, known from the equations of the theory of elasticity, may still be of interest. The present paper is a report of an experimental test of that phenomenon.

APPARATUS AND EXPERIMENTAL TECHNIQUE

The experiments were carried out by photoelastic methods. Fig. 1 shows the general arrangement of the installation and Fig. 2 a diagrammatic representation of the experimental apparatus. The apparatus had been designed so that it could be placed between the optical elements of a typical photoelastic bench.

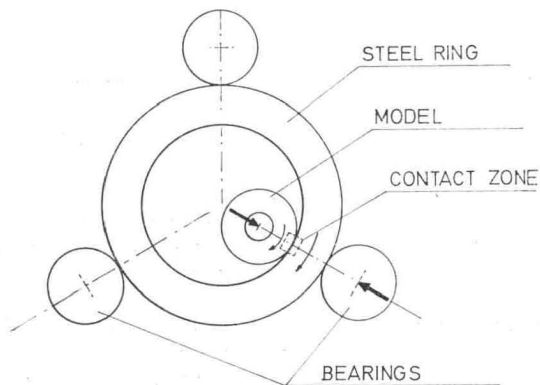

FIG. 2.

The subjects of investigation were a cylinder made of CR-39 plastic material, 4.7 in. dia. and 0.7 in. thick, loaded up to $p_0 = 4300$ psi and a glass cylinder 4.8 in. dia. and 1 in. thick loaded up to $p_0 = 30,000$ psi, p_0 denoting the maximum pressure of the contact point according to Hertz' theory. The steel ring, which was of 11 in. i.d., was supported on three bearings. Great care was taken in the manufacture of the apparatus to ensure that the axes of the cylinder, the ring and the bearings were parallel. The load was applied to the contact point by means of a lever and spring as shown in Fig. 1.

The ring and the cylinder were driven by separate motors to facilitate rolling and sliding contacts. The ring was driven by a constant-speed motor by means of a rubber belt. The transmission allowed the speed of the ring to be varied. For the experiment reported here the speed of the track of the ring was $V_p = 122, 346$ and 680 in/sec. The cylinder was driven by a variable-speed d.c. motor which enabled the peripheral speed of the cylinder to be varied within the range of $V_w = 0$ to $V_w = 1400$ in/sec.

The velocities of the ring and the cylinder were measured by means of photo-cells and recorded. The error of speed measurement was estimated at about 3 per cent.

Oils of various viscosities were sprayed onto the surface of the ring and the cylinder.

The isochromatic pattern was photographed by means of a parallel beam of monochromatic light ($\lambda = 4470 \text{ \AA}$) produced by a flash lamp. The time of exposure was about $1 \mu\text{sec}$.

In order to verify the correctness of operation of the apparatus and the optical sensitivity of the model material used, photographs of the isochromatic pattern were taken by applying a load to the cylinder when static and under conditions of rolling at various speeds. No differences were observed between the static and dynamic isochromatic patterns for dry contact. This means that the materials used for the cylinders showed neither elastic nor optical hysteresis within the range of speeds applied.

Fig. 3 shows the isochromatic pattern for dry contact using a glass cylinder. A unit load of $P = 1180$ lb/in. produces according to Hertz, a maximum pressure of $p_0 = 23,000$ psi. In this stress-pattern the fringes are loci of constant shear stress τ in the plane of the cylinder. From the stress optical law¹ the shear stress is given by the equation

$$\tau = nF.$$

The maximum fringe order n_{max} and, therefore, the maximum shear stress τ_{max} occur in the interior of the cylinder just below the surface of contact. With the photographic

technique used the smallest difference that could be measured was approximately one-quarter of a fringe. When working at a level of 15 fringes, differences of 1.6 per cent can be measured.

In the author's earlier investigations,⁴ the plastic model of the cylinder had a layered structure. The outer layers were made of an organic glass, optically insensitive and the middle layer of CR-39 model material. Such a cylinder structure facilitated the determination of contact stresses in the central layer of the cylinder. The investigation proved that for the considered range of ratio of oil film thickness to width, side leakage may be neglected.

In order that the results may be compared with those obtained by other authors, the usual coefficients characterizing the contact conditions were used.²

These coefficients varied within the following limits. The velocity parameter

$$U = \frac{\mu_0 V_p}{E' R} = 2.10 \cdot 10^{-10} \text{ to } 10.10 \cdot 10^{-10}.$$

The load parameter,

$$W = \frac{P}{E' R}, \quad \begin{cases} W = 10^{-4}, & \text{for the plastic model and} \\ W = 1.05 \cdot 10^{-5} \text{ to } 1.42 \cdot 10^{-5} & \text{for the glass model.} \end{cases}$$

The material parameter,

$$G = \alpha E', \quad \begin{cases} G = 160, & \text{for the plastic model and} \\ G = 2600, & \text{for the glass model.} \end{cases}$$

RESULTS

Fig. 4 shows the isochromatic pattern in the contact zone obtained for the plastic model rolling on the lubricated surface. The isochromatic pattern is seen to differ from that for dry contact. This must be an effect of the change in pressure distribution between the cylinder and the ring.

Figs. 5(a) and (b) and 6(a) and (b) show typical sets of stress-patterns obtained for a plastic and a glass model, respectively, under dry and lubricated conditions. Other conditions such as those of total contact load and the speed and slip in the given set are identical. A comparison of the pictures (a) and (b) enables us to conclude that under the conditions of measurement the oil film exerts an influence on the stress distribution in the contact zone, and the pressure distribution differs considerably from the Hertzian distribution.

The stress-patterns obtained under lubricated conditions are non-symmetrical. The isochromatics are far apart at the entry and dense at the exit. This indicates different pressure gradients in the front and rear part of the contact zone. Under lubricated conditions the maximum fringe order n_{\max} is lower than that for dry contact. This fact is of particular importance because it indicates that the presence of an oil film reduces the maximum shear stress in the contact zone. For the sets shown in Figs. 5 and 6, n_{\max} is reduced under lubricated conditions by 20 and 33 per cent, respectively. The change of the isochromatic pattern in the neighbourhood of the surface of the cylinder indicates that the surface transmitting the load under lubricated conditions is increased by about two to three times that for dry contact.

Some interesting information is furnished by comparing the isochromatic patterns of Figs. 5(b) and 6(b). Both have been obtained under lubricated conditions of contact, and differ by the load and the elastic properties of the model.

The isochromatic pattern shown in Fig. 5(b) for a plastic model corresponds to the analysis of the phenomenon based on the assumption of a deformable cylinder and constant viscosity of oil. The isochromatic pattern of Fig. 6(b) for the glass model, corresponds to the analysis in which the deformability of the cylinder and the variability of the oil viscosity under the pressure have been accounted for. (For mineral oil a pressure of $p_0 = 30,000$ psi causes an increase in viscosity by some fifty times.)

On the basis of the photographs of the isochromatic pattern we can obtain directly some information on the influence of oil on the effective stress in the material.

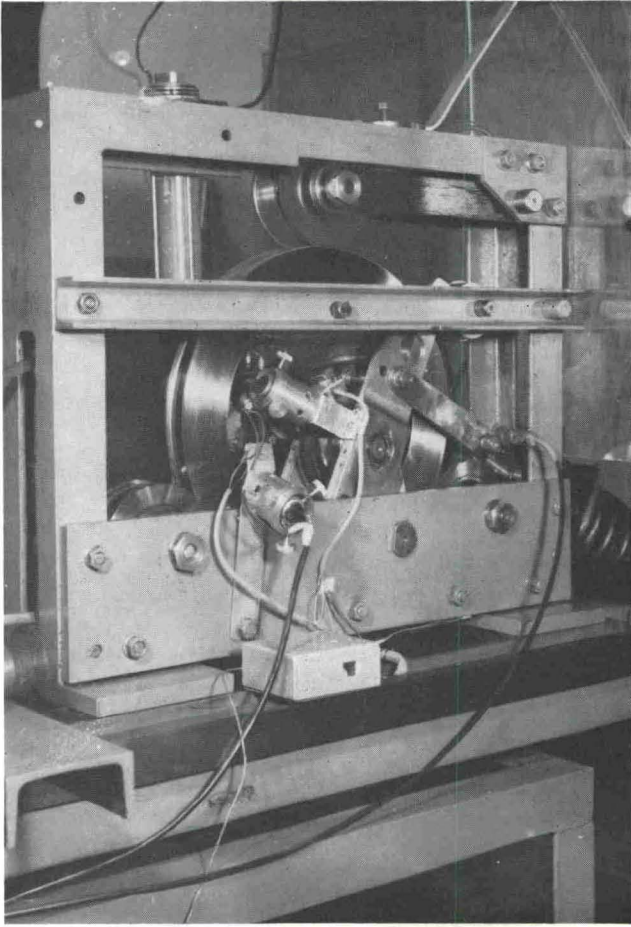

FIG. 1.

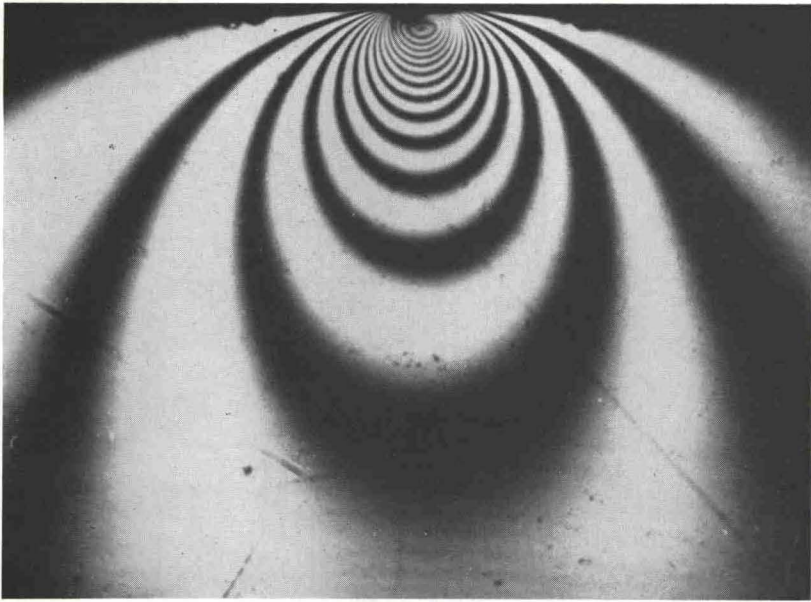

FIG. 3.



FIG. 4.

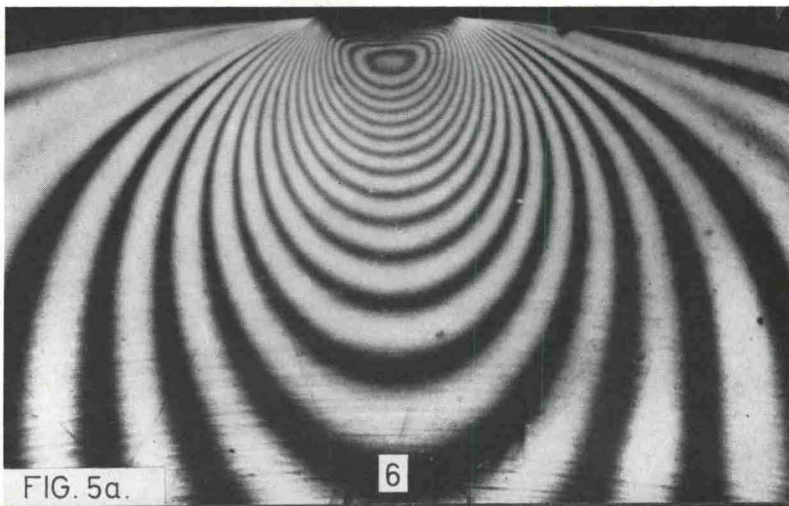

FIG. 5a.

6

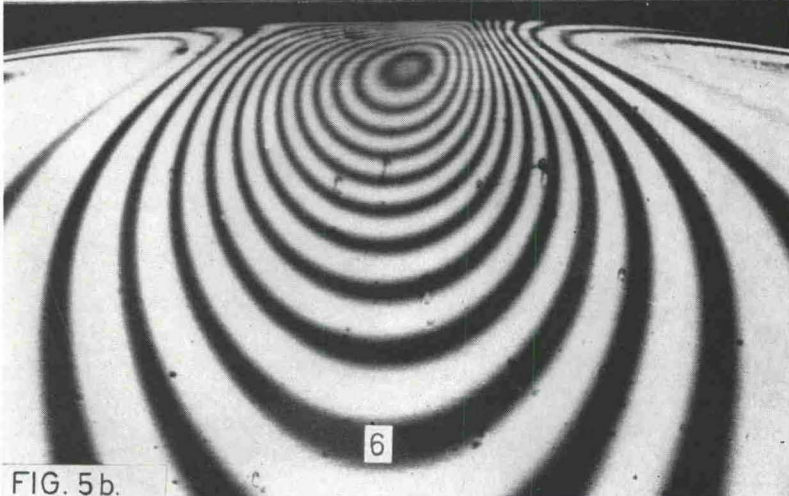

FIG. 5b.

6

FIG. 5.

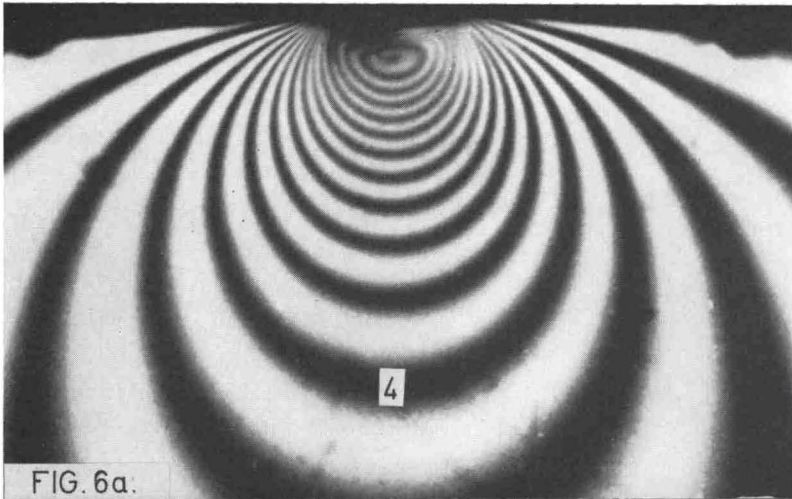

FIG. 6a.

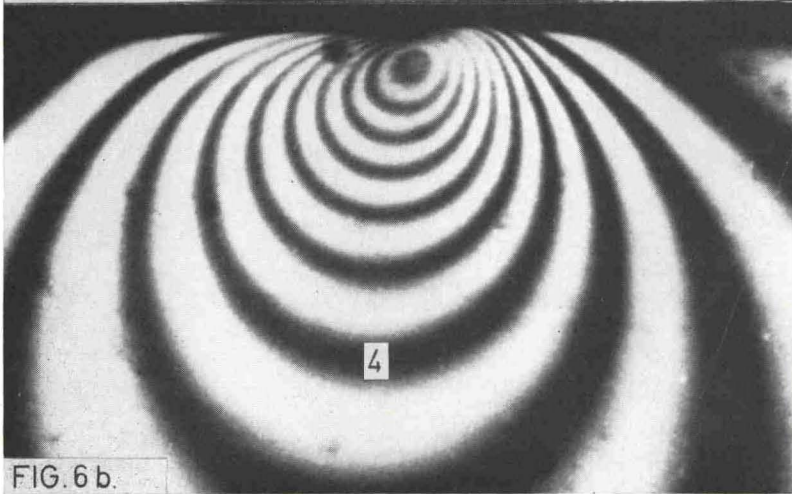

FIG. 6b.

FIG. 6.

The coefficient of relative reduction of shear stress is

$$\mathcal{H} = \frac{\tau_{\max} \text{ with oil}}{\tau_{\max} \text{ dry}} = \frac{n_{\max} \text{ with oil}}{n_{\max} \text{ dry}}$$

For a glass model, diagrams of \mathcal{H} have been plotted on the basis of sets of photographs as shown in Fig. 6(a) and (b) as a function of the velocity of the ring V_p and slip coefficient β . The diagrams have been drawn for constant load producing a maximum Hertzian pressure for dry contact, $p_0 = 23,000$ psi. Gear oils Hipol 15 and Spirax 90 EP with a viscosity $\mu_0 = 810$ cP and $\mu_0 = 690$ cP respectively, at the temperature of 65°F were used.

Fig. 7 shows the effect of the different track speeds of the ring V_p on the coefficient \mathcal{H} for small slips of $-0.4 < \beta < 0.4$.

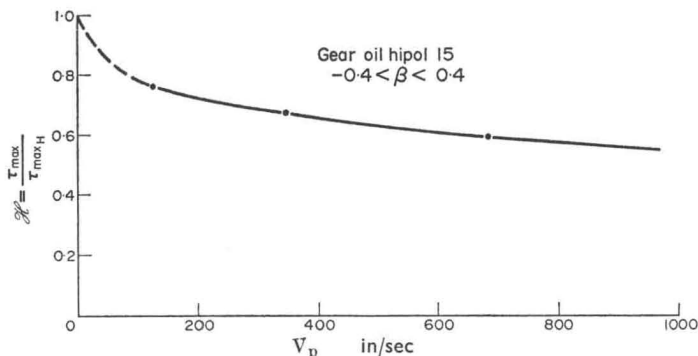

FIG. 7.

It is seen from this graph that the influence of the velocity on the value of the coefficient \mathcal{H} is considerable for small velocities, $V_p < 150$ in/sec. Above this value \mathcal{H} does not undergo a great change.

The diagrams in Figs. 8, 9 and 10 illustrate the influence of the slip coefficient $\beta = (V_w/V_p) - 1$ on the coefficient \mathcal{H} . The points given in the figures correspond to the sets of photographs as shown in Fig. 6(a) and (b). For low velocities (Fig. 8), an increase in slip causes an increase in the influence of the oil film. This may be explained by the increase of the contact velocity $V = (V_p + V_w)/2$.

For the highest velocities (Fig. 10), the coefficient $\mathcal{H} = 0.56$; this seems to be independent of the coefficient β in the entire range tested $-1 < \beta < 1$. This means that the maximum shear stress in the contact zone is less by 44 per cent for lubricated conditions than for dry contact. The average error of measurements of \mathcal{H} was estimated at about 5 per cent.

The isochromatic patterns obtained enable us also to determine the pressure distribution in the oil film. In order to determine the stress at any point of the contact zone the method of characteristics was used³ enabling the stresses to be determined from the isochromatics only.

The equilibrium equations of an element of the body are

$$\frac{\partial p}{\partial x} - 2Fn \sin 2\phi + 2Fn \cos 2\phi \frac{\partial \phi}{\partial y} = -F \left(\cos 2\phi \frac{\partial n}{\partial x} + \sin 2\phi \frac{\partial n}{\partial y} \right),$$

$$\frac{\partial p}{\partial y} + 2Fn \cos 2\phi \frac{\partial \phi}{\partial x} + 2Fn \sin 2\phi \frac{\partial \phi}{\partial y} = -F \left(\sin 2\phi \frac{\partial n}{\partial x} - \cos 2\phi \frac{\partial n}{\partial y} \right),$$

they involve the unknowns $p = \frac{1}{2}(\sigma_1 + \sigma_2)$ and the angle ϕ which determines the direction of the principal stress in the assumed system of axes.

In addition there occur the quantities,

$$\sigma_1 - \sigma_2 = 2Fn,$$

where F is the model constant; $\partial/\partial x$ and $\partial/\partial y$ denote derivatives in the system of assumed co-ordinates. The above equations constitute a hyperbolic set and have two families of

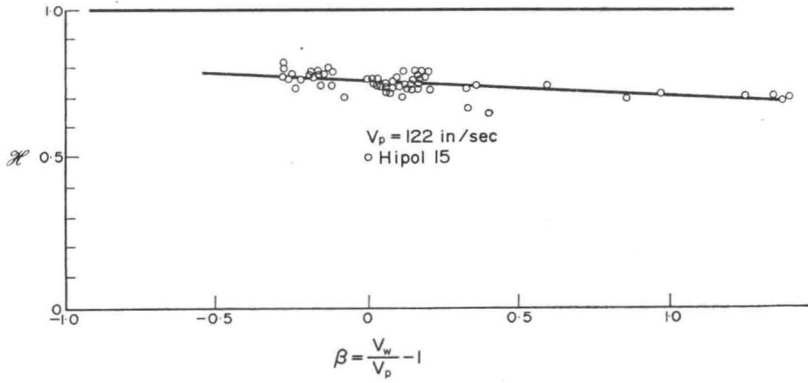

FIG. 8.

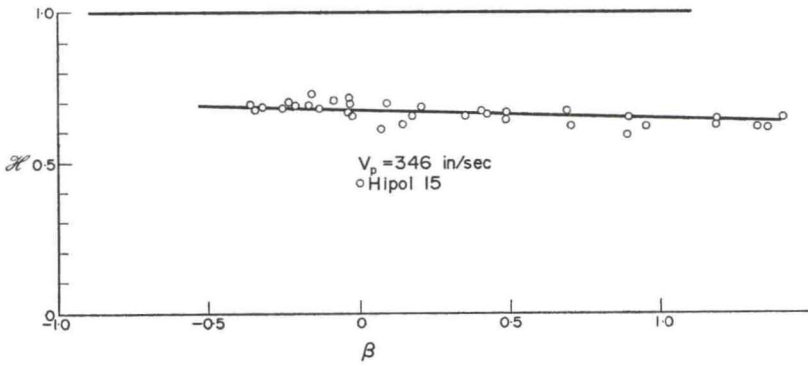

FIG. 9.

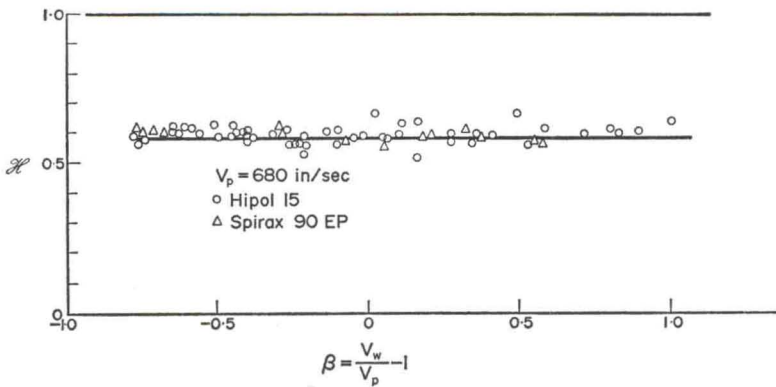

FIG. 10.

real characteristics. Integration of the characteristic equations was carried out in an approximate manner by means of finite differences and by a step-by-step procedure.

Fig. 11 gives the isochromatic pattern taken for computation, from which two families of characteristics have been obtained, see Fig. 12. With what is known from the theory

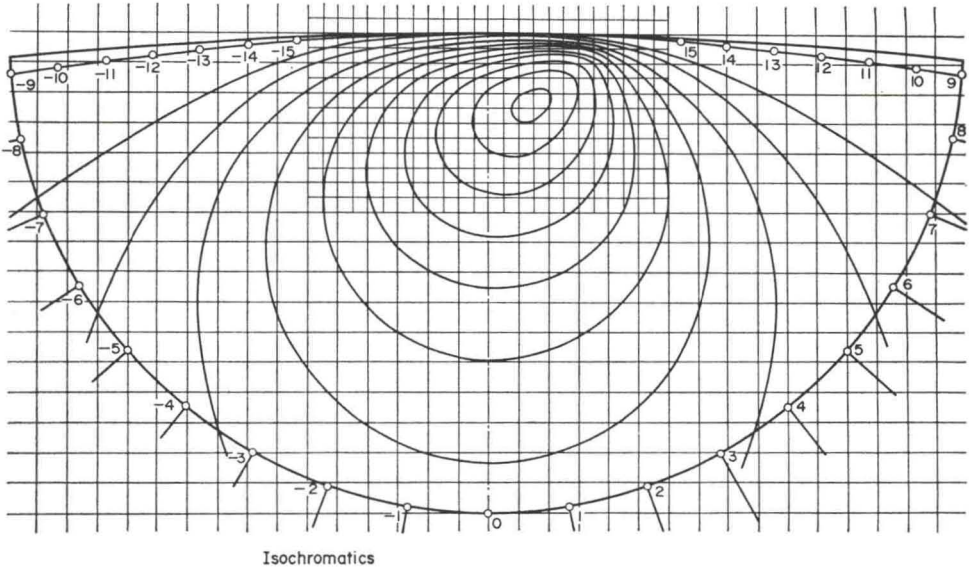

FIG. 11.

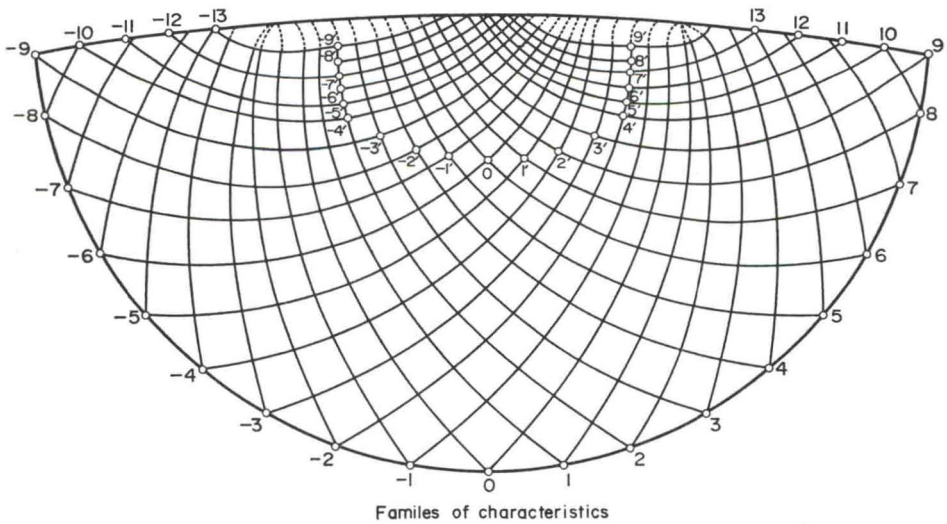

FIG. 12.

of elasticity, stresses at the points $-13 \dots -9 \dots 0 \dots +9 \dots +13$ were used as starting values, and calculations were made in the characteristic directions, until the points closed onto the contact surface. Thereafter the stresses on the contact surface were extrapolated. The pressure distribution in the oil film thus obtained is shown in Fig. 13.

CONCLUSIONS

As a result of the measurements, the stress distribution in the contact zone has been obtained as a function of rolling speed, the slip, the load and the properties of oil. The rolling speeds applied in the measurements correspond with those in real structures, which is essential in view of the time of passage of the oil through the contact zone ($t = 10^{-4}$ sec).

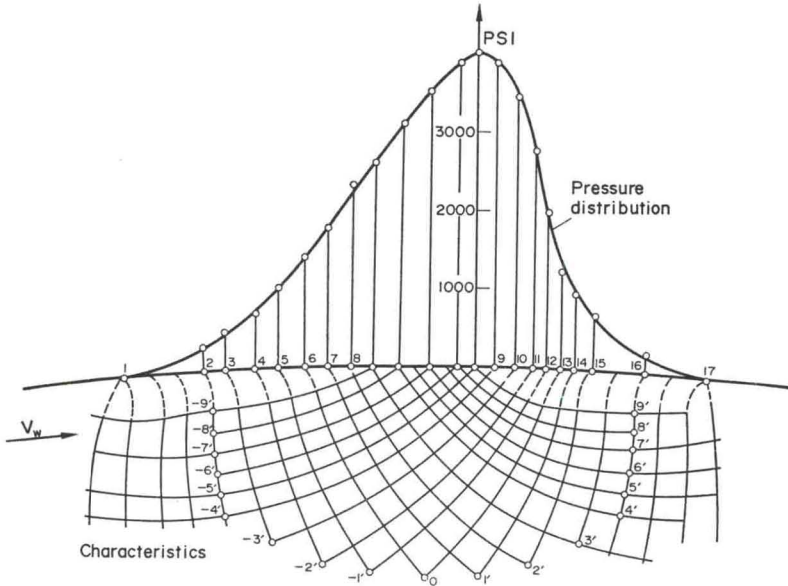

FIG. 13.

The choice of glass as the model material enables pressures in the contact zone to approach the real ones met with in toothed gears and roller bearings. The model material possesses a modulus of elasticity not dissimilar to that of engineering materials conventionally used in rolling contacts, i.e. steel, bronze, etc.

The results obtained show a distinct influence of the oil film on the value and distribution of the contact stresses.

This influence is as follows: (1) The oil film between the surface of the rolling elements reduces the maximum contact stresses. For the contact conditions of measurement, this influence is from 20 to 40 per cent by reference to the Hertz stresses obtained for dry contact. In some cases the effective stress in the contact zone was observed to be reduced by some 50 per cent. (2) The isochromatic patterns for pure rolling show that for the condition of measurement used, the point of maximum shear stress has no tendency to move towards the edge of the cylinder. (3) The influence of the oil film on the contact stress in the small velocity zone ($V_p < 150$ in./sec) depends in a marked manner on the rolling speed; for higher velocities it undergoes small variations, see Fig. 7. (4) The greater distance between the isochromatics in the inlet zone and their greater density in the exit zone show that the gradients of increase

and decrease of the pressure in the oil film differ considerably. No sharp second pressure maximum, which was to be expected theoretically in the neighbourhood of the exit, was observed on an isochromatic pattern.

REFERENCES

1. M. M. FROCHT, *Photoelasticity*. New York (1941).
2. D. DOWSON, Proceedings International Symposium on Lubrication and Wear, Berkeley (1965).
3. W. SZCZEPIŃSKI, *Arch. Mech. Stos.* **13**, 579 (1961).
4. J. STUPNICKI, *Arch. Bud. Maszyn.* **12**, 48 (1965).